

www.PublicFurniture.com

Phone: 1-888-863-2888

Fax: 1-888-863-2858

Park Serie - Picnic table

#460/1/2/3/8

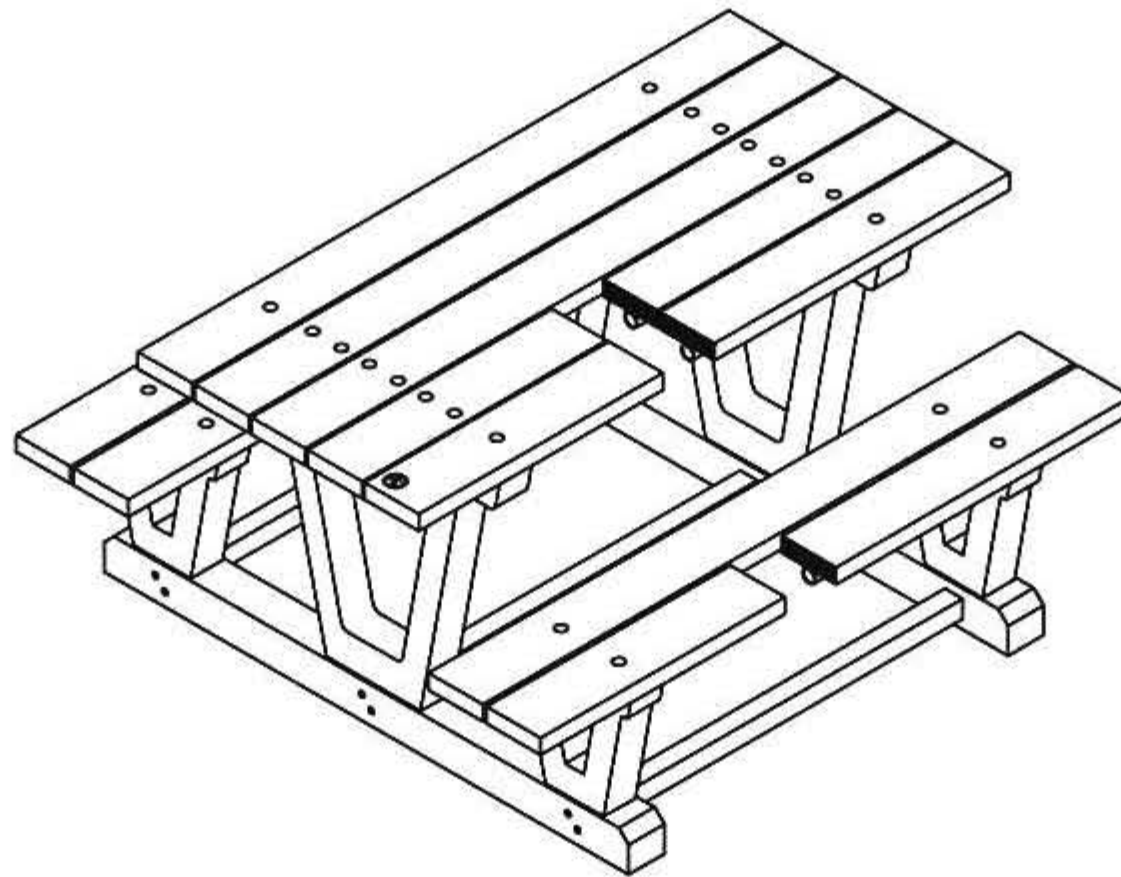
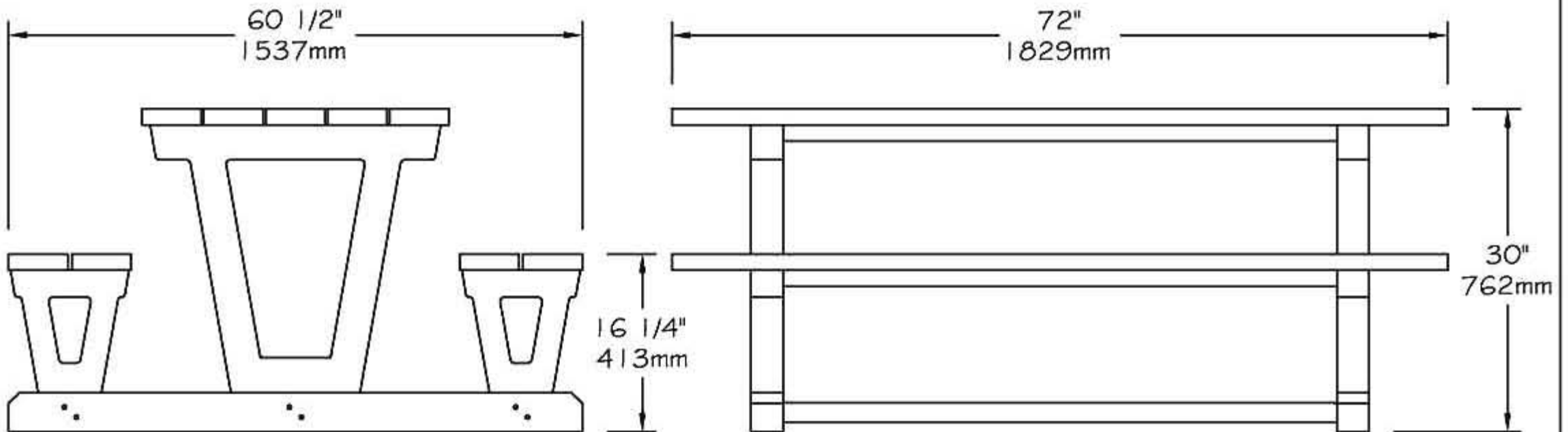

Picnic table #460, #461, #462, #463, #468 "Park-Série"

- The table is completely made of **ULTRAPLAST™** recycled plastic.
- The table structure is black and the slats are available in grey (#450), brown (#452), green (#454), sand (#458) or red wood (#451).
- The seat and table slats, 2" x 6" (37mm x 137mm) in **ULTRAPLAST™** recycled plastic, are reinforced with a aluminium pipe Ø1 15/16" x 60" (Ø49mm x 1524mm).
- The legs are made of black **ULTRAPLAST™** recycled plastic. Machine screws are inserted in the plastic during molding to fix the table and seat slats.
- Hidden Hardware.
- Dimensions: 96" x 60 1/2" x 30" (2437mm x 1537mm x 762mm).
- Available installation : surface mounted.
- Shipped ready to be assembled.

Standard installation details:

- Surface mounted.

Options:

- Stainless steel standard anchor #KB.
- Stainless steel antitheft anchor #OAN.
- Factory assembly.

Picnic table, **ULTRAPLAST™**, weight : 392 Lb.